



**ITB-17-03
ADDENDUM #1
2017 OVERLAY PROJECT**

JHM

Date: April 12, 2017
Bid Number: ITB-17-03
Bid Due Date: THURSDAY, MAY 9, 2017 BY 1:00 PM OUR CLOCK

The following information is provided to all prospective bidders and is hereby made a part of the above bid documents. Bidders must acknowledge this Addendum 1 with their bid. It is a total of five pages, plus a one-page ITB-17-03 2017 Overlay Map pdf.

CLARIFICATION, ADDITIONAL INFORMATION, AND CHANGES:

During the conversion from Word to pdf, page 5 inadvertently became a blank page in the initial posting of the bid document. The Table of Contents has been corrected, see revisions with this Addenda.

Details regarding Bid Alternate #3 are found on the attached document.

Three pages of Standard Construction Details for this project are included with this addendum.

A map showing the streets to be included for the 2017 Overlay work, is available as a pdf document, posted separately.

Please note the location of the pre-bid meeting on April 20th at 11 AM is:

Wheat Ridge City Hall
7500 W. 29th Ave.
Wheat Ridge, CO 80033

Visit our City website for prebid sign in sheet, addendum, plan holders list and project updates:
www.ci.wheatridge.co.us

POINT OF CONTACT: Jennifer Nellis, Purchasing Agent, jnellis@ci.wheatridge.co.us, fax 303-234-5924, or phone 303-235-2811. Do not contact the user department, consultant, or any other staff.

TABLE OF CONTENTS

	<u>PAGE #</u>
SIGNATURE PAGE	3
ADVERTISEMENT FOR BIDS.....	4
INFORMATION FOR BIDDERS	6
CONTRACTORS QUALIFICATION FORM.....	11
PROPOSAL FORM	19
BID SCHEDULE.....	21
LIST OF SUBCONTRACTORS	28
NON-DISCRIMINATION ASSURANCE FORM.....	29
ILLEGAL ALIEN COMPLIANCE FORM.....	30
KEEP JOBS IN COLORADO CERTIFICATION STATEMENT	31
NON COLLUSION AFFIDAVIT	32
BID BOND FORM	33
SAMPLE AGREEMENT & FORMS	34
GENERAL PROVISIONS.....	43
CITY STANDARD SPECIAL PROVISIONS	
Section 100 - General	53
Section 202 - Removal of Structures	65
Section 203 - Excavation & Embankment	67
Section 210 - Reset Structures	69
Section 304 - Aggregate Base Course	70
Section 403 - Hot Bituminous Pavement	72
Section 412 - Concrete Pavement.....	73
Section 604 - Manholes, Inlets and Meter Vaults	74
Section 608 - Sidewalks & Bikeways	75
Section 609 - Curb & Gutter.....	77
Section 614 - Traffic Control Devices	78
Section 627 - Pavement Marking.....	97
Section 630 - Traffic Control	98
Section 720 - Material Sampling & Testing.....	100
STANDARD CONSTRUCTION DETAILS.....	
LIST OF STREETS (informational only).....	
DRAWINGS (map)	
PROJECT PLANS	
ADDENDA (if applicable)	

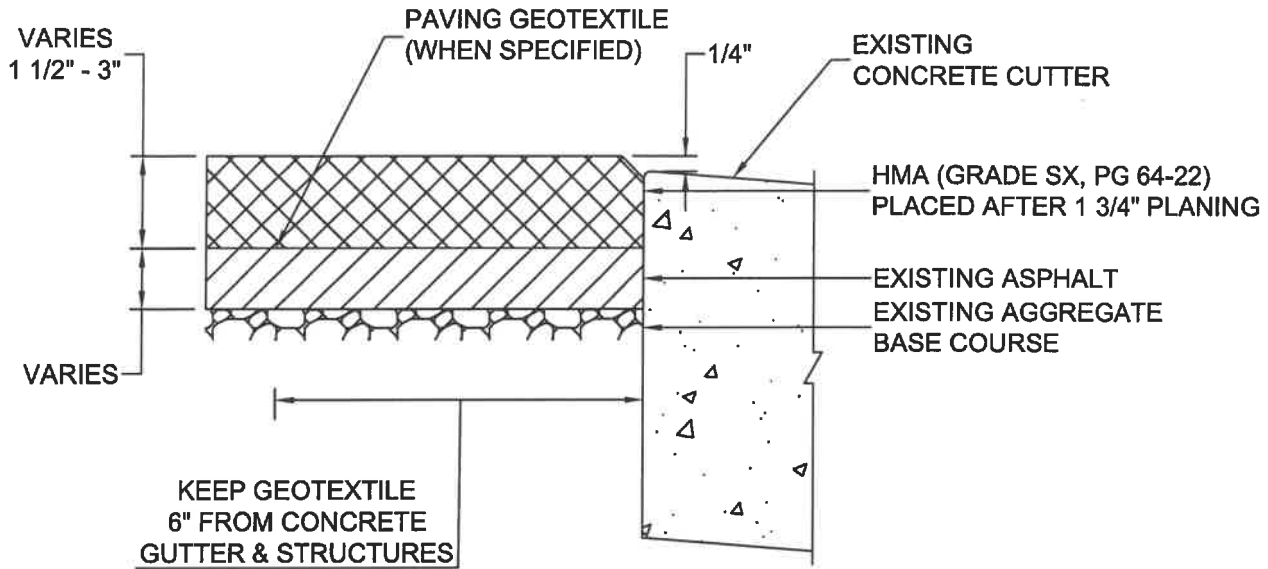

NOTE: PROVIDE TACK COAT WHEN GEOTEXTILE IS NOT SPECIFIED.

ASPHALT PLANING & HMA OVERLAY

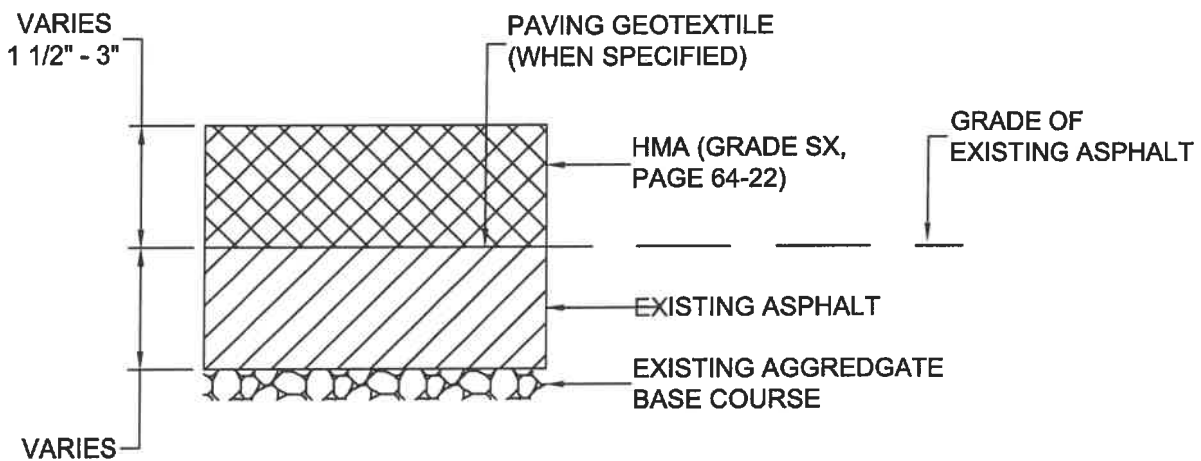

NOTE: PROVIDE TACK COAT WHEN GEOTEXTILE IS NOT SPECIFIED.

HMA OVERLAY

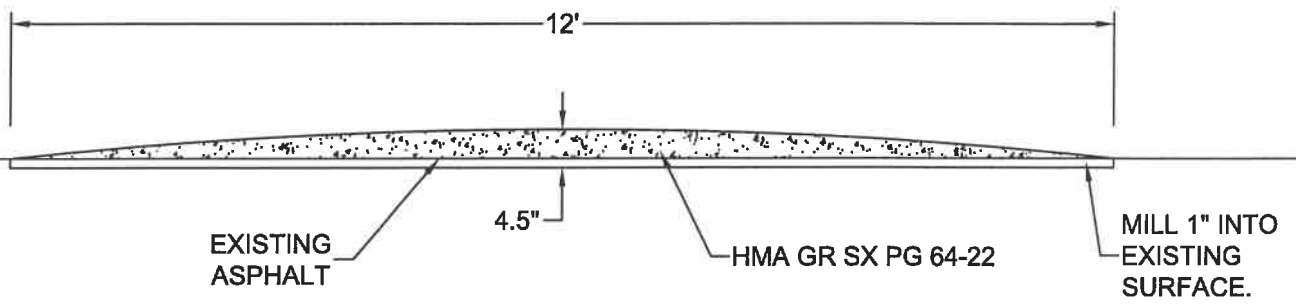

HMA SPEED HUMP

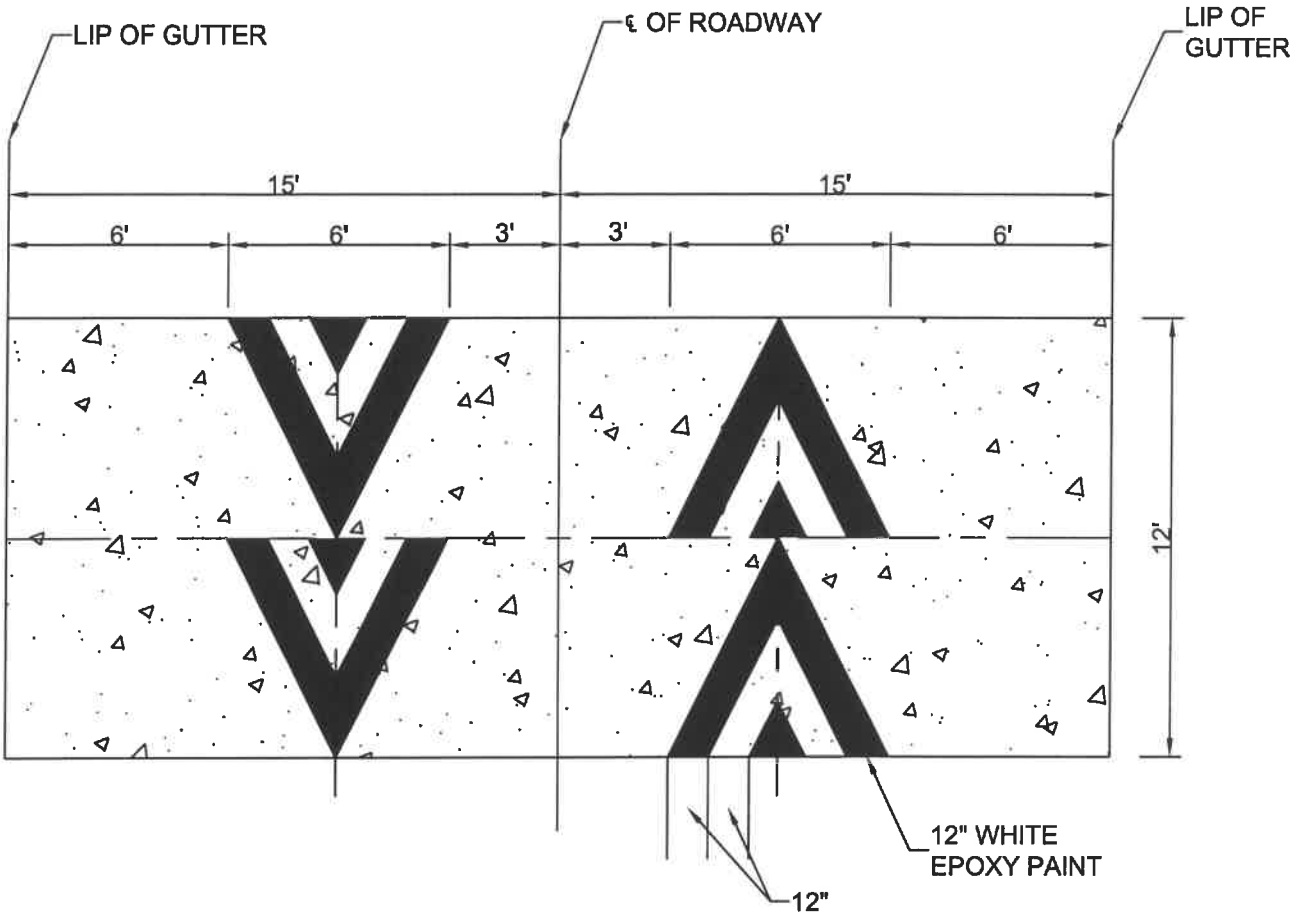

PAVEMENT MARKING FOR HMA SPEED HUMP